



# INSTRUCTION MANUAL DUAL TONE DECODER

MODEL 3185C S/N \_\_\_\_\_

IF FOR SOME REASON YOU HAVE TO  
RETURN THIS ITEM TO THE FACTORY  
FOR ANY SERVICE OR REPAIR, YOU  
MUST CONTACT CUSTOMER SERVICE  
FOR A RMA NUMBER 716-765-2254

P/N 1340022

REVISION DATE 7/90

**M** **MONROE ELECTRONICS, INC.**  
**E** 100 Housel Avenue, Lyndonville, N.Y. 14098  
Phone: 716-765-2254 • Telex: 75-6662 • FAX: 716-765-9330

---

**TABLE OF CONTENTS**

DESCRIPTION ..... 1

SPECIFICATIONS ..... 2

INSTALLATION ..... 3

  Mounting ..... 3

  Pin Numbers and Functions ..... 3

  FIGURE 1 ..... 4

  FIGURE 2 ..... 4

  Audio Input Connection ..... 5

  Set Input Connection ..... 5

  Reset Input Connection ..... 5

  Relay Output Connection ..... 5

  Power Supply Input ..... 6

CUSTOMER OPTIONS ..... 6

  FIGURE 3 ..... 7

  Input Impedance ..... 7

  Input Balanced/Unbalanced ..... 7

  5 Minute Restoral ..... 7

  20 Minute Reset ..... 7

  J10 ..... 8

  Output Relay ..... 8

  Number of Digits to Decode ..... 9

  Fourth Digit ON/OFF ..... 9

  FIGURE 4 ..... 10

CODE SELECTION ..... 11

OPERATION ..... 11

  Operating With a 4-Digit Code ..... 12

  Operating With a 3-Digit Code ..... 12

  Operating With a 2-Digit Code ..... 12

  Operating With a 1-Digit Code ..... 12

ADJUSTMENTS ..... 12

RETURN POLICIES AND PROCEDURES ..... 13

  Factory Repair ..... 13

  Expedited Factory Repair ..... 13

  Factory Repair to Modified Equipment ..... 13

WARRANTY ..... 14

3185C/1 SCHEMATIC

3185C/22 PC BOARD LAYOUT

REVISION 7/90 FOR CHANGE OF 80131-2.00 SOFTWARE FOR J10.

#### DESCRIPTION

The Model 3185C Dual Tone Decoder is capable of accepting a sequence of up to four dual tone signal inputs such as those from a Touch-Tone <sup>(R)</sup> telephone key pad. It provides a relay closure as its output. Standard features include:

- Dual Form C Relay Output
- Selectable Input Impedance
- Selectable Balanced/Unbalanced Input
- Adjustable Input Signal Range
- Restoral of Output Status if Power Interruption is Less Than 5 Minutes.
- Selectable 20 Minute Relay Output Reset
- Digit Sequence Selectable up to Four Digits
- Selectable Relay Output Action (latching, momentary, or alternate).
- Level Sensitive "Reset" Input
- Level Sensitive "Set" Input

---

**SPECIFICATIONS**

Input Coupling ..... AC

Input Impedance:  
  Factory Setting ..... 10 K $\Omega$  Minimum  
  Selectable ..... 600  $\Omega$  Terminated

Input:  
  Factory Setting ..... Unbalanced  
  Selectable ..... Balanced

Common Mode Range .....  $\pm$  5 Volts

Input Signal Range:  
  Minimum ..... 44 mV p-p  
  Maximum ..... 13.8 V p-p

Input Range:  
  Normal ..... -24 dBm to +6 dBm  
  Optional .....  $\pm$ 10 dBm Adjustable

Digit Validation Time ..... 40 ms Minimum

Inter-Digit Time:  
  Minimum ..... 40 ms  
  Maximum ..... 3 Seconds

Maximum Digits Per Second:  
  No Twist ..... 13  
   $\pm$  6 dB ..... 12

Relay Output ..... DPDT 30 VDC @ 2 Amp.

Reset Line ..... Level Sensitive  
  Minimum 20  $\mu$ s Pulse  
  to Ground.

Set Line ..... Level Sensitive  
  Minimum 20  $\mu$ s Pulse  
  to Ground.

Edge Connector ..... Monroe Model 3000RK  
  (Cinch Jones 50-  
  20A-30)

Power Requirements ..... 12 Volts D.C.  $\pm$ 10%  
  200 mA Maximum.

Physical Dimensions ..... 5.0 in.H X 3.0 in.W  
  X 0.6 in.D

## INSTALLATION

### Mounting:

The Model 3185C is designed to plug into a Monroe 3000RK 20-pin edge connector. All connections are intended to be made at the edge connector and will be referred to in this manual by edge connector number or letter.

### Pin Numbers and Function:

Pin numbers are listed below for the Model 3185C when plugged into a 3000RK Connector. Consult FIGURE 1 page 4 for proper registration of pin numbers.

PIN NUMBER	FUNCTION
1	Common terminal for relay output referenced to pins 9 and 10.
2	Circuit common (ground).
3	Circuit common (ground).
5	Audio input low (audio input circuit common if unbalanced).
6	Audio input high.
8	+12 Volt D.C. power supply input.
9	Normally closed contact for relay output referenced to pins 1 and 10.
10	Normally open contact for relay output referenced to pins 1 and 9.
A	Common terminal for relay output referenced to pins K and L.
B	Not used at present time. Connections made at this pin will cause the 3185C to stop functioning.
D	"Set" input.
E	"Reset" input.
K	Normally closed contact for relay output referenced to pins A and L.
L	Normally open contact for relay output referenced to pins A and K.

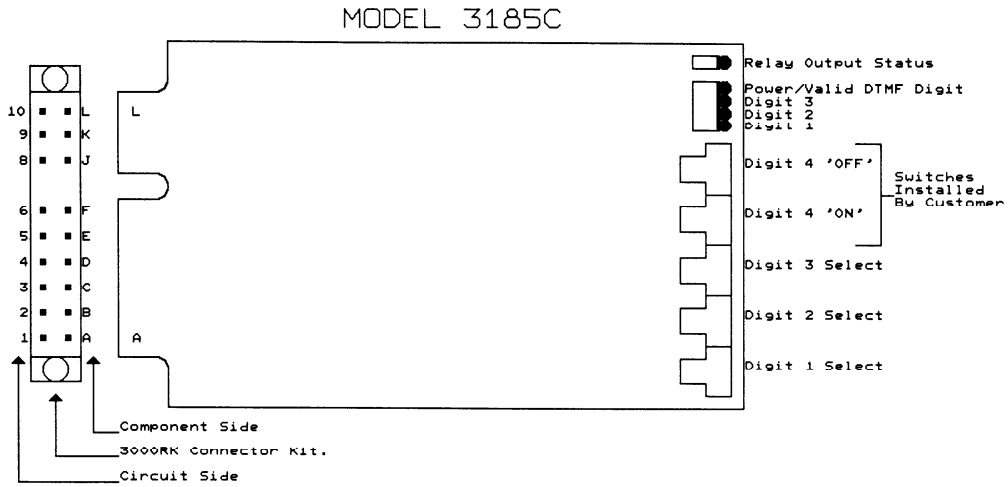

FIGURE 1  
Edge Connector, Switch, and Indicator Locations

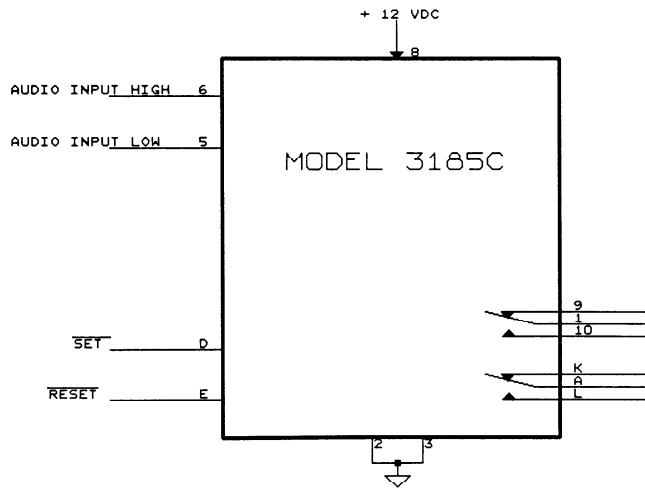

FIGURE 2  
BLOCK DIAGRAM

Audio Input Connection:

The audio input is connected at pins "6" and "5" (circuit common). The 3185C is factory set at 10 K $\Omega$  input impedance; unbalanced. This audio input may be changed by the customer to have a 600  $\Omega$  termination instead of 10 K $\Omega$ , and also to be balanced instead of unbalanced. Consult the CUSTOMER OPTION section for more explanation.

Set Input Connection:

The Set input is connected at pin "D", and when pulsed to circuit common will energize the output relay. The output relay will remain energized until the proper "OFF" code is received or the reset input is pulsed to ground. This input is level sensitive and requires a minimum pulse width of 20  $\mu$ sec. to circuit common to activate the output relay. The set input has presedents over all functions except reset.

If the 3185C's set input is pulsed to circuit common while decoding a code sequence it will clear previous digit(s) decoded. Clearing previous digit(s) decoded by the 3185C is performed after the pulse at the set input is removed from circuit common.

Reset Input Connection:

Momentarily connecting pin "E" to circuit common will cause the 3185C to reset. This input is level sensitive and requires a minimum pulse of 20  $\mu$ sec. to circuit common to reset the card. The reset input dominates over all other functions.

**NOTE:** The 3185C will ignore all commands or code sequences until the reset input is removed from circuit common.

Relay Output Connections:

The 3185C provides a dual Form C relay output. The output relay will energize whenever the preprogrammed "ON" code sequence is received, or the set input is connected to circuit common. The output relay will remain energized until the preprogrammed "OFF" code sequence is received, or the reset input is connected to circuit common.

The dual Form C relay output connections are shown below:

RELAY OUTPUT	COMMON CONTACT	NORMALLY CLOSED CONTACT	NORMALLY OPEN CONTACT
1 FORM C	1	9	10
1 FORM C	A	K	L

Power Supply Input:

The power supply input is connected to pins 8 (+12 VDC) and 3 (circuit common). The 3185C requires a power supply capable of providing 200 mA minimum, and regulation of the +12 volt,  $\pm 10\%$ .

**CUSTOMER OPTIONS**

The Model 3185C is factory set to the following:

- Input Impedance: 10 K $\Omega$
- Input: Unbalanced
- 5 Minute Restoral: Enabled
- 20 minute Reset: Disabled
- Output Relay Latching
- 4 Digit Decode Sequence
- \* for Fourth Digit "ON"
- # for Fourth Digit "OFF"

**NOTE:** When selecting customer options (J1 through J5) use a 25 watt soldering pencil, flux-cored solder of an alloy of 60% tin and 40% lead, and solder removal braid. The circuit traces on the 3185C are very thin and using any pressure on these traces will cause the traces to detach from the PC board. After soldering, remove the flux off the PC board with FREON TMC or ISOPROPYL ALCOHOL.

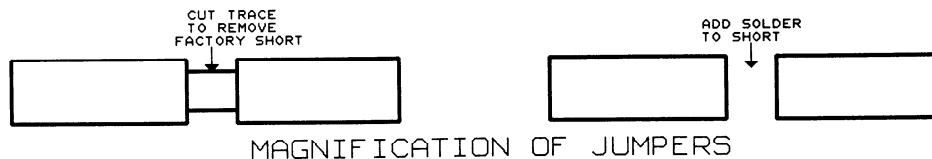



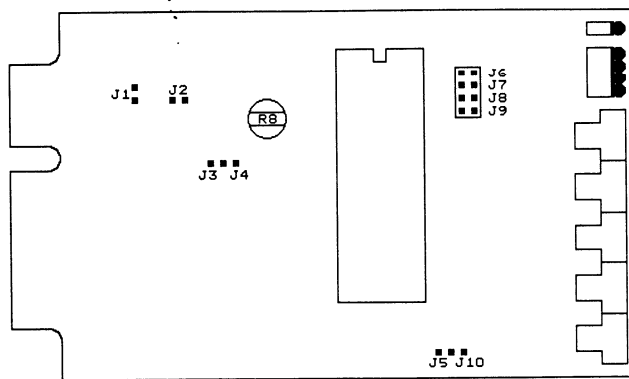

NUMBER OF DIGITS	J8	J9
1	X	X
2	X	0
3	0	X
4	0	0

RELAY OUTPUT MODE	J6	J7
LATCHING	0	0
MOMENTARY	X	0
ALTERNATE	0	X

X = JUMPER INSTALLED  
0 = JUMPER REMOVED

RB = INPUT SIGNAL LEVEL RANGE ADJUSTMENT

	JUMPER	OPEN	SHORTED
INPUT IMPEDANCE	J1	10 KΩMS*	600 ΩMS
INPUT TERMINATION	J2	BALANCED	UNBALANCED*
5 MINUTE RESTORAL	J3		ENABLED*
5 MINUTE RESTORAL	J4		DISABLED
20 MINUTE RESTORAL	J5	DISABLED*	ENABLED

\* = FACTORY SETTING

FIGURE 3  
JUMPER LOCATIONS

**Input Impedance:**

Input impedance may be either 10 KΩ or 600 Ω. The J1 jumper determines the input impedance of the 3185C. Install a short across the J1 jumper to make the audio input terminated to 600 Ω. Consult FIGURE 3 for the J1 jumper location.

**Input Balanced/Unbalanced:**

The input may be selected to be balanced or unbalanced. The J2 jumper determines whether the input is balanced or unbalanced. Removing the short from J2 jumper will make the input balanced. Consult FIGURE 3 for the J2 jumper location.

**5 Minute Restoral:**

The 3185C may be selected to restore the output status for a power interruption of less than five minutes. The 3185C is shipped from the factory with this restoral enabled. The J3 jumper is shorted with the J4 jumper open. To disable the five minute restoral install a short on J4. Consult FIGURE 3 for the J3 and J4 jumper location.

**20 Minute Reset:**

A 20 minute reset is provided to reset the output relay 20 minutes after the "ON" code is received or the set input is pulsed to circuit common. This option is factory set disabled. To

enable the 20 minute reset install a short on J5. Consult FIGURE 3 page 7 for the J5 jumper location.

**J10:**

J10 on the 3185C is set at the factory and should not be changed when software 80131-1.00 is used. If software 80131-2.00 is installed J10 may be selected in the field. When J10 is open the 3185C's output will operate as explained for J6,J7 installation. When J10 is installed the output relay is set in momentary operation with J6 and J7 removed. This setting (J10 installed) requires a 'ON' code to energize the output relay for 240 mSec. and then a 'OFF' code to energize the relay again for 240 mSec. Also the 5 minute restoral is disabled when J10 is installed.

**Output Relay:**

The output relay on the 3185C may be set in three different modes of operation: latching, momentary, or alternating. The 3185C is factory set at latching.

Being set at latching means the output relay will energize when the preprogrammed "ON" code is received or the set input pulsed to circuit common. The output relay will remain energized until the preprogrammed "OFF" code is received or the reset input is pulsed to circuit common.

When the output relay is programmed to operate in the momentary mode, it will energize for the duration that the last valid digit is present. In the momentary mode the 3185C will not respond to its preprogrammed "OFF" code.

Alternate action programs the relay for latching relay output. In this mode the output relay energizes and de-energizes with the same preprogrammed "ON" code sequence.

The programming of jumpers for the output relay is shown below. Consult FIGURE 3 page 7 for the "J6" jumper and the "J7" jumper location.

RELAY OUTPUT MODE	JUMPER	
	J6	J7
LATCHING	0	0
MOMENTARY	X	0
ALTERNATE	0	X

X = JUMPER INSTALLED  
0 = JUMPER REMOVED

Number of Digits to Decode:

The 3185C is factory set to decode a 4-digit "ON" code sequence and a 4-digit "OFF" code sequence. The first three digits of the code sequence are the same for "ON" or "OFF". The fourth digit for the "ON" code sequence is factory set to "\*", and the fourth digit for the "OFF" code sequence is factory set to "#". The number of digits to decode is determined by jumpers "J8" and "J9". Consult FIGURE 3 page 7 for the location of "J8" and "J9". The programming of jumpers for the number of digits to decode is shown below:

NUMBER OF DIGITS	JUMPER	
	J8	J9
1	X	X
2	X	0
3	0	X
4	0	0

X = JUMPER INSTALLED  
0 = JUMPER REMOVED

Fourth Digit ON/OFF:

The fourth digit of the "ON" code sequence and the fourth digit of the "OFF" code sequence are factory set at "\*" and "#" respectively, by traces on the 3185C. To change the preset fourth digit ON code and the fourth digit OFF code of the 3185C, hexadecimal rotary switches must be added, by the customer to the 3185C. When ordering hexadecimal rotary switches use Monroe Electronics part number "9200002".

Before adding switches to the 3185C the customer must cut traces on the circuit side of the board to remove the preset \* and # code settings.

Consult FIGURE 4 page 10 for location of traces to be cut.

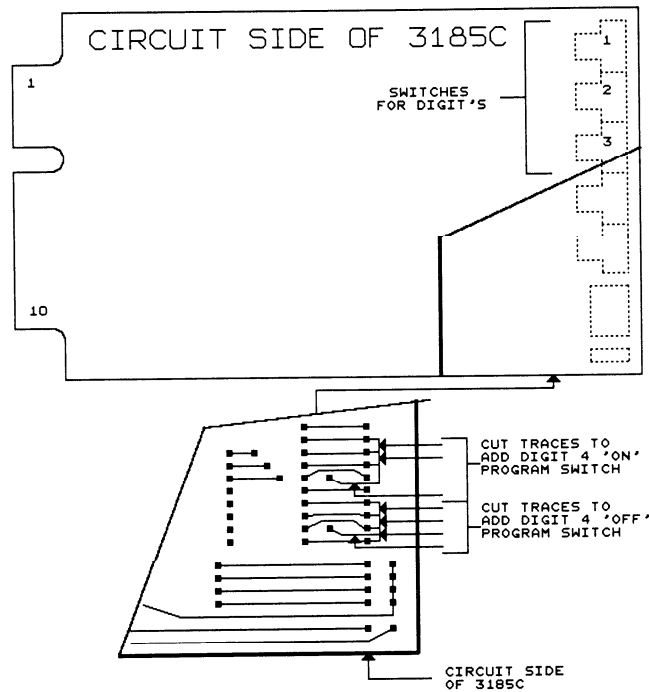

FIGURE 4  
MODIFYING BOARD FOR PROGRAM SWITCHES

Upon cutting all the correct traces as shown in FIGURE 4 install the switches using a 25 watt solder pencil and good quality flux-cored solder of an alloy of 60% tin and 40% lead (60/40). It is important that after soldering the solder joints be cleaned with a solvent such as Freon TMC or Isopropyl Alcohol.

---

#### CODE SELECTION

Each digit in the code sequence is determined by the hexadecimal rotary switches on the front edge of the 3185C. 0 through D select the corresponding DTMF digit to be decoded. The letter "E" on the rotary switch represents the "\*" DTMF digit and the letter "F" on the rotary switch represents the "#" DTMF digit.

As stated before, the 3185C is factory set to decode a 4-digit "ON" code sequence and a 4-digit "OFF" code sequence. The first three digits of the code sequence are the same for "ON" and "OFF". The fourth digit for the "ON" code sequence is factory set

switch settings each time a code sequence is received.

Consult FIGURE 1 page 4 for location of switches and designation of switches.

#### OPERATION

When the 3185C is connected to a DC power source, the Power/Valid Digit LED will be illuminated on the front edge of the PC board. This LED indicator will continue to illuminate until a valid DTMF digit is detected or DC power is removed from the board.

The 3185C's LED indicators D1, D2, and D3 illuminate for correct DTMF digit(s) decoded for the preprogrammed code sequence. D1 illuminates for the correct first digit in the preprogrammed code sequence. D2 illuminates for the correct second digit in the preprogrammed code sequence, and D3 illuminates for the correct third digit in the preprogrammed code sequence.

The relay output status indicator on the front edge of the 3185C illuminates whenever the output relay is energized.

Upon decoding a valid digit in the preprogrammed code sequence, the 3185C will wait for the next valid digit in the code sequence. If the time between digits from the beginning of the first digit valid is more than three seconds, the 3185C will reset and wait for the first digit in the preprogrammed code sequence.

Operating With a 4-Digit Code:

When a 4-digit code sequence is programmed into the 3185C the switch program is as follows:

SWITCH 1 = FIRST DIGIT OF THE CODE SEQUENCE FOR "ON" OR "OFF".  
SWITCH 2 = SECOND DIGIT OF THE CODE SEQUENCE FOR "ON" OR "OFF".  
SWITCH 3 = THIRD DIGIT OF THE CODE SEQUENCE FOR "ON" OR "OFF".  
SWITCH 4 = FOURTH DIGIT OF THE CODE SEQUENCE FOR "ON" (preset to "\*" if switch not installed).  
SWITCH 5 = FOURTH DIGIT OF THE CODE SEQUENCE FOR "OFF" (preset to "#" if switch not installed).

If the 3185C is programmed for momentary relay output or alternating relay output SWITCH 5 is not used for programming.

Operating With a 3-Digit Code:

When a 3-digit code sequence is programmed into the 3185C the switch program is as follows:

SWITCH 1 = FIRST DIGIT OF CODE SEQUENCE FOR "ON" OR "OFF".  
SWITCH 2 = SECOND DIGIT OF CODE SEQUENCE FOR "ON" OR "OFF".  
SWITCH 3 = THIRD DIGIT OF CODE SEQUENCE FOR "ON".  
SWITCH 4 = THIRD DIGIT OF CODE SEQUENCE FOR "OFF" (preset to "\*" if switch not installed).

If the 3185C is programmed for momentary relay output or alternating relay output SWITCH 4 is not used for programming.

Operating With a 2-Digit Code:

When a 2-digit code sequence is programmed into the 3185C the switch program is as follows:

SWITCH 1 = FIRST DIGIT OF CODE SEQUENCE FOR "ON" OR "OFF".  
SWITCH 2 = SECOND DIGIT OF CODE SEQUENCE FOR "ON".  
SWITCH 3 = SECOND DIGIT FOR CODE SEQUENCE FOR "OFF".

If the 3185C is programmed for momentary relay output or alternating relay output SWITCH 3 is not used for programming.

Operating With a 1-Digit Code:

When a 1-digit code sequence is programmed into the 3185C the switch program is as follows:

SWITCH 1 = FIRST DIGIT OF CODE SEQUENCE FOR "ON".  
SWITCH 2 = FIRST DIGIT OF CODE SEQUENCE FOR "OFF".

If the 3185C is programmed for momentary relay output or alternating relay output SWITCH 2 is not used for programming.

**ADJUSTMENT**

R8 permits the user to adjust the level of the received DTMF tones. This adjustment would be made when the received audio levels are too low or too high to permit reliable decoding.

---

Setting R8 fully counterclockwise will provide -10 dBm of gain.  
Setting R8 fully clockwise will provide +10 dBm of gain.

Consult FIGURE 3 page 7 for the location of R8.

#### RETURN POLICIES AND PROCEDURES

##### FACTORY REPAIR:

Return authorization is required for factory repair work.

Material being returned to the factory for repair must have a return material authorization number. To obtain a RMA number, call 716-765-2254 and ask for the service department.

Material returned to the factory for warranty repair must be accompanied by a copy of a dated invoice or bill of sale which serves as a proof of purchase for the material.

Repairs will be returned promptly. Repairs are normally returned to the customer by UPS within ten working days after they are received by Monroe Electronics, Inc. Return (to the customer) UPS charges will be paid by Monroe Electronics on warranty work. Return (to the customer) UPS charges will be prepaid and added to invoice for out-of-warranty repair work.

##### EXPEDITED FACTORY REPAIR:

All material returned to the factory by air or by an overnight service will be expedited.

Expedited factory repairs will be returned to the customer by the same mode of transportation by which the material was returned to the factory for repair (i.e. material returned to the factory by an overnight service will be returned to the customer by an overnight service).

**NOTE:** Return (to the customer) transportation expenses for expedited factory repairs will always be at the expense of the customer regardless of the warranty status of the equipment.

##### FACTORY REPAIRS TO MODIFIED EQUIPMENT:

Material returned to the factory for repair which has been modified will be not tested unless the nature and purpose of the modification is understood by us and does not render the equipment untestable at our repair facility.

We will reserve the right to deny service to any modified equipment which is returned to the factory for repair regardless of the warranty status of the equipment.

#### **WARRANTY**

Monroe Electronics, Inc. warrants to the Owners, each instrument and sub-assembly manufactured by them to be free from defects in material and workmanship for a period of one year after shipment from factory. This warranty is applicable to the original purchaser only.

Liability under this warranty is limited to service, adjustment or replacement of defective parts (other than tubes, fuses, or batteries) on any instrument or sub-assembly returned to the factory for this purpose, transportation charges prepaid.

This warranty does not apply to instruments or sub-assemblies subjected to abuse, abnormal operating conditions, or unauthorized repair or modification.

Since Monroe Electronics, Inc. has no control over conditions of use, no warranty is made or implied as to the suitability of our product for the customer's intended use.

**THE WARRANTY SET FORTH IN THIS ARTICLE IS EXCLUSIVE AND IN LIEU OF ALL OTHER WARRANTIES AND REPRESENTATIONS, EXPRESS, IMPLIED OR STATUTORY INCLUDING, BUT NOT LIMITED TO THE IMPLIED WARRANTIES OF MERCHANTABILITY AND FITNESS.** Except for obligations expressly undertaken by Monroe Electronics, in this Warranty, Owner hereby waives and releases all rights, claims and remedies with respect to any and all warranties, express, implied or statutory (including without limitation, the implied warranties of merchantability and fitness), and including but without being limited to any obligation of Monroe Electronics with respect to incidental or consequential damages, or damages for loss of use. No agreement or understanding varying or extending the warranty will be binding upon Monroe Electronics unless in writing signed by a duly authorized representative of Monroe Electronics.

In the event of a breach of the foregoing warranty, the liability of Monroe Electronics shall be limited to repairing or replacing the non-conforming goods and/or defective work, and in accordance with the foregoing, Monroe Electronics shall not be liable for any other damages, either direct or consequential.



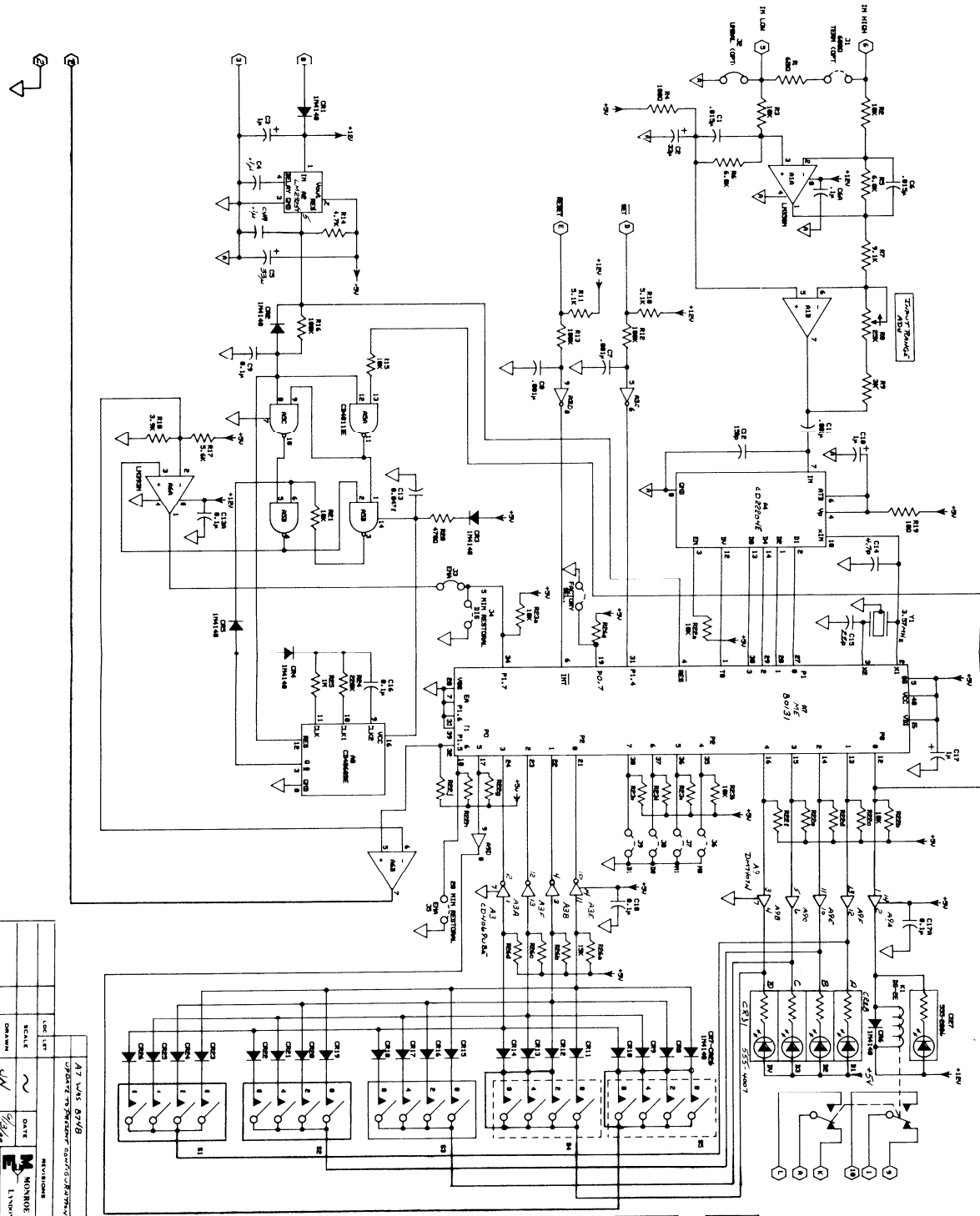

REV. NO.	DATE	DESCRIPTION
0	5/25/90	INITIAL
1	5/25/90	ADDED C49
2	5/25/90	REVISION
3	5/25/90	REVISION
4	5/25/90	REVISION
5	5/25/90	REVISION
6	5/25/90	REVISION
7	5/25/90	REVISION

C ADDED C49 5/25/90  
 D REVISION 5/25/90  
 A1 A4 WAS 2520MP 5/25/90  
 A1 CURELIS VALUE & STYLE CHANGE 5/25/90

3/13/88

DESIGNER	DATE	SCALE	CHK'D BY
WJ	5/25/90	1:1	WJ
APP'D BY	DATE	SCALE	CHK'D BY
WJ	5/25/90	1:1	WJ
<b>MINOR ELECTRONICS, INC.</b> LYONSVILLE, VA 24185			
<b>MODEL 3AB5C</b>			

3/13/88

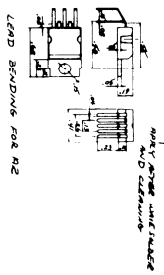
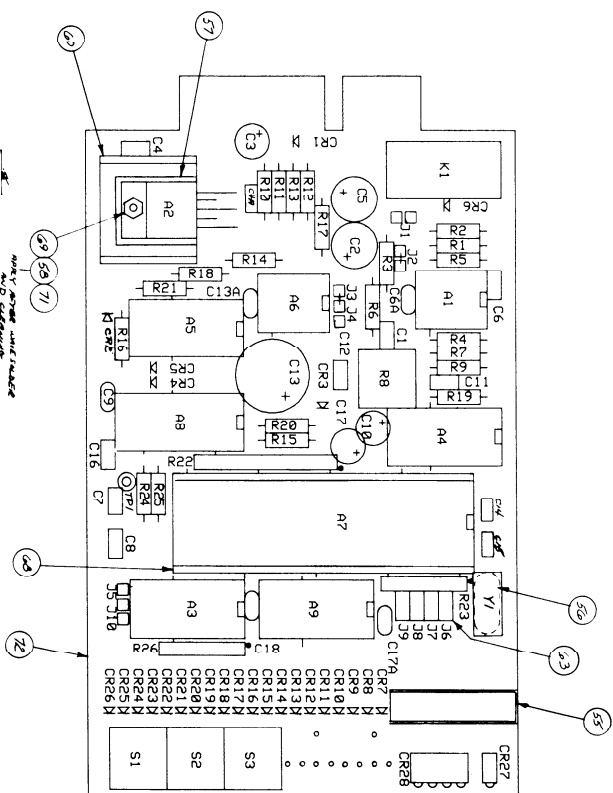

REV	DESCRIPTION	DATE	BY
15	REWORK CASE	11-5-57	90
14	RE WORK W/TS 8-1, 10, 20, 21, 22, 23, 24, 25, 26, 27, 28, 29, 30, 31, 32, 33, 34, 35, 36, 37, 38, 39, 40, 41, 42, 43, 44, 45, 46, 47, 48, 49, 50, 51, 52, 53, 54, 55, 56, 57, 58, 59, 60, 61, 62, 63, 64, 65, 66, 67, 68, 69, 70, 71, 72, 73, 74, 75, 76, 77, 78, 79, 80, 81, 82, 83, 84, 85, 86, 87, 88, 89, 90, 91, 92, 93, 94, 95, 96, 97, 98, 99, 100	11-5-57	90
13	REWORK W/TS 8-1, 10, 20, 21, 22, 23, 24, 25, 26, 27, 28, 29, 30, 31, 32, 33, 34, 35, 36, 37, 38, 39, 40, 41, 42, 43, 44, 45, 46, 47, 48, 49, 50, 51, 52, 53, 54, 55, 56, 57, 58, 59, 60, 61, 62, 63, 64, 65, 66, 67, 68, 69, 70, 71, 72, 73, 74, 75, 76, 77, 78, 79, 80, 81, 82, 83, 84, 85, 86, 87, 88, 89, 90, 91, 92, 93, 94, 95, 96, 97, 98, 99, 100	11-5-57	90
12	REMOVED I.L. SOCKET FROM A8	11-5-57	90
11	REMOVED I.L. SOCKET FROM A8	11-5-57	90
10	REMOVED I.L. SOCKET FROM A8	11-5-57	90
9	REMOVED I.L. SOCKET FROM A8	11-5-57	90
8	REMOVED I.L. SOCKET FROM A8	11-5-57	90
7	REMOVED I.L. SOCKET FROM A8	11-5-57	90
6	REMOVED I.L. SOCKET FROM A8	11-5-57	90
5	REMOVED I.L. SOCKET FROM A8	11-5-57	90
4	REMOVED I.L. SOCKET FROM A8	11-5-57	90
3	REMOVED I.L. SOCKET FROM A8	11-5-57	90
2	REMOVED I.L. SOCKET FROM A8	11-5-57	90
1	REMOVED I.L. SOCKET FROM A8	11-5-57	90

REV	DESCRIPTION	DATE	BY
1	REMOVED I.L. SOCKET FROM A8	11-5-57	90

REV	DESCRIPTION	DATE	BY
1	REMOVED I.L. SOCKET FROM A8	11-5-57	90

MINIATURE UNIT NUMBER  
 IN C. C. DRAWING

LEAD BENDING FOR A2

MODEL 3-135C  
 ASSY DRAWING

MINIATURE UNIT NUMBER  
 IN C. C. DRAWING

LEAD BENDING FOR A2

MODEL 3-135C  
 ASSY DRAWING

MINIATURE UNIT NUMBER  
 IN C. C. DRAWING

LEAD BENDING FOR A2

MODEL 3-135C  
 ASSY DRAWING

MINIATURE UNIT NUMBER  
 IN C. C. DRAWING

LEAD BENDING FOR A2

MODEL 3-135C  
 ASSY DRAWING